

Barcode Scan Engines

MT752

This product range
was provided by
admatec GmbH





MT 752 (5V CCD Scan Engine)

MT 752L (3.3V CCD Scan Engine)

Hardware Development Specification



CONTENTS

TABLE OF CONTENTS

1. INTRODUCTION	3
1-1. MT752 / MT752L Block Diagram	3
1-2. Pin Assignment	4
2. GENERAL SPECIFICATIONS	6
2-1. Input power requirements	6
2-2. Power consumption	6
2-3. Scanning performance	6
2-4. Interface	7
2-5 Physical Requirements	7
3. ENVIRONMENTAL CONDITIONS	7
3-1. Operation temperature	7
3-2. Storage temperature	7
3-3. Relative humidity	7

4. READING SPECIFICATIONS	8
4-1. Symbologies	8
4-2. Reading direction	8
4-3. Operating mode	8
4-4. SCANNING RANGE	9
5. MECHANICAL INTERGRATION	10
5-1. Mechanical Dimensions	10
5-2. Mounting a window	11
5-3. Window aperture & placement.....	13
5-4. Tilt angle, pitch, and skew angle	14
5-5. Curvature degree	16
5-6. Ribbon cable specification.....	16
6. Downloading Firmware.....	17
7. APPLICATION	23
8. SAFETY APPROVAL	24
9. VERSION HISTORY	24

1. INTRODUCTION

The **MT752 / MT752L** CCD engine is a high performance CCD Barcode scanning and decoding apparatus designed for optimal performance and easy integration. It is suitable for a wide range of retail and industrial applications, and also meets industry standard form factor requirements. **MT752** is a 5VDC CCD engine module for wide-angle reading application. **MT752L** is a 3.3VDC CCD engine module for mobile device barcode wide-angle reading application.

1-1. **MT752 / MT752L** Block Diagram

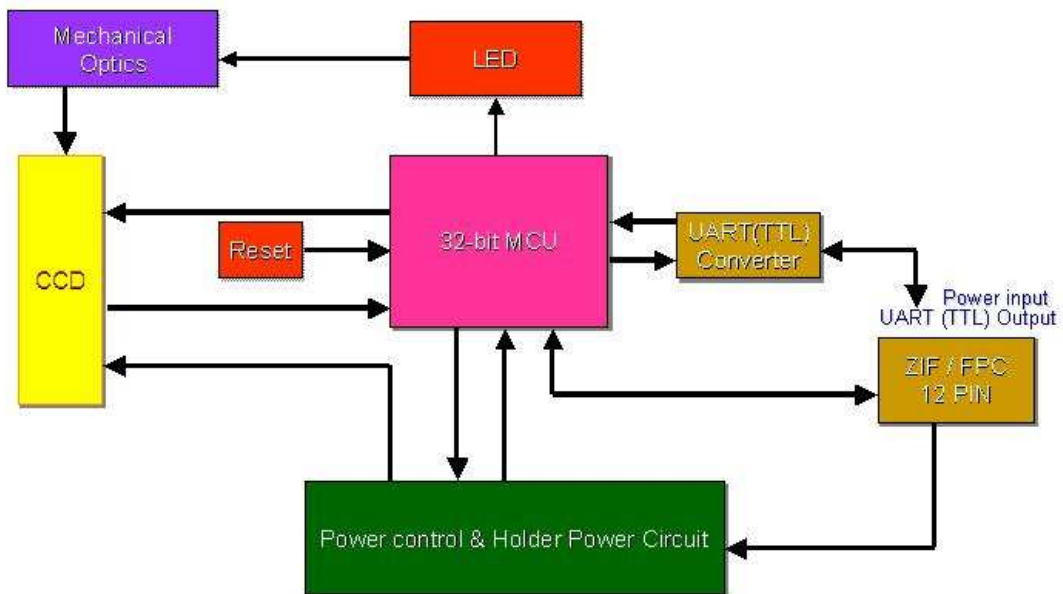

1-2. Pin Assignment

Contact assignment [MT752 / MT752L](#) Decoded Operations

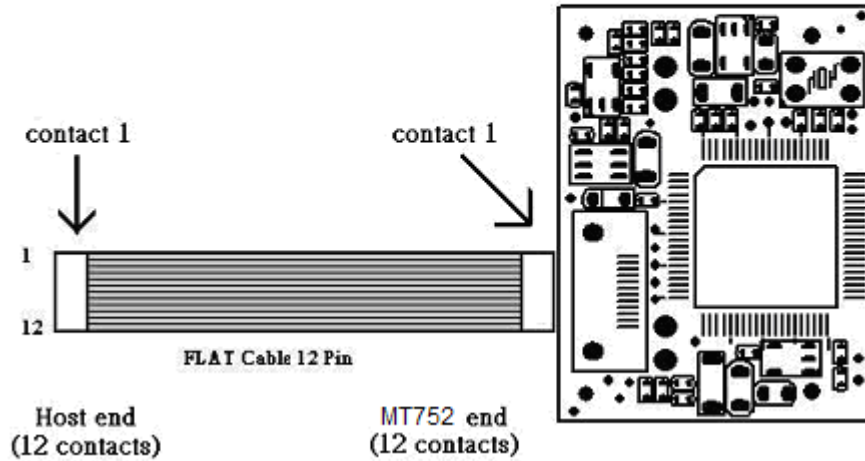

Ribbon cable connections



Contact assignment (host side of flex ribbon cable)

12 contacts- decoded operation

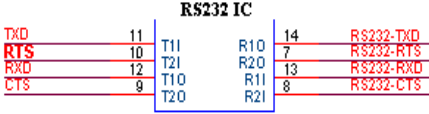
MT752 MT752L Pin Assignment			Decoded operation	Electrical Equivalency																												
1	VCC	-----	Scan engine power supply. Must always be connected to a 5V /3.3V power supply	3.3V / 5V ←																												
2	RXD	INPUT	Serial input (UART) reception from host system For Firmware update use	<table border="1"> <thead> <tr> <th colspan="4">RS232 IC</th> </tr> </thead> <tbody> <tr> <td>TXD</td> <td>11</td> <td>T11</td> <td>R10</td> <td>14</td> <td>RS232-TXD</td> </tr> <tr> <td>RTS</td> <td>10</td> <td>T21</td> <td>R20</td> <td>7</td> <td>RS232-RTS</td> </tr> <tr> <td>RXD</td> <td>12</td> <td>T21</td> <td>R11</td> <td>13</td> <td>RS232-RXD</td> </tr> <tr> <td>CTS</td> <td>9</td> <td>T20</td> <td>R21</td> <td>8</td> <td>RS232-CTS</td> </tr> </tbody> </table>	RS232 IC				TXD	11	T11	R10	14	RS232-TXD	RTS	10	T21	R20	7	RS232-RTS	RXD	12	T21	R11	13	RS232-RXD	CTS	9	T20	R21	8	RS232-CTS
RS232 IC																																
TXD	11	T11	R10	14	RS232-TXD																											
RTS	10	T21	R20	7	RS232-RTS																											
RXD	12	T21	R11	13	RS232-RXD																											
CTS	9	T20	R21	8	RS232-CTS																											

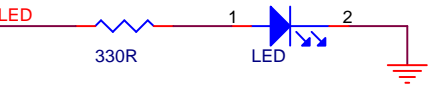
3	Trigger	INPUT	<p>0:= Lighting on Scan engine reads, decodes and sends information to the host system.</p> <p>1= Lighting off Scan engine stops reading , decoding and transmitting information.</p>	<hr style="border-top: 1px dashed black;"/>
4	Power enable	INPUT	<p>0:= scan engine on 1= scan: engine off , except: * during data transmission * writing setup parameters to no non-volatile memory.</p>	<p>For MT742L (3.3V) model connected this pin to control power enable by host side</p> <p>When power is off, the power consumption is < 1uA.</p> <hr style="border-top: 1px dashed black;"/>
5	TXD	OUTPUT	<p>Serial output (UART) transmission to host system</p> <p>For Firmware update use</p>	
6	RTS	OUTPUT	<p>Scan engine requests permission from host to transmit on TXD line.</p>	
7	GND	-----	Ground	
8	USB_D+	I/O	USB data (+)	<hr style="border-top: 1px dashed black;"/>
9	LED	OUTPUT	CCD Engine Status display	

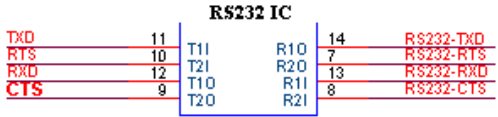
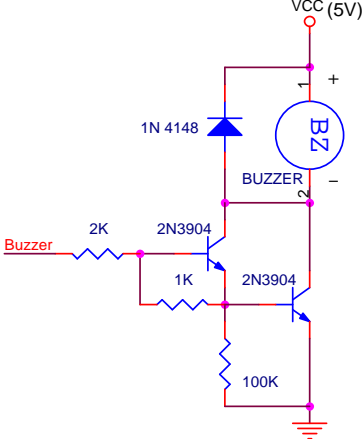
10	CTS	INPUT	Host authorizes scan engine to transmit on TXD line (RTX/CTS hardware protocol).	
11	Buzzer	OUTPUT	Active = barcode successfully decoded. Low level= inactive awaiting decode	
12	USB_D-	I/O	USB data (-)	-----

Note: Define these I/O characteristics for internal operate voltage VDD=3.3v (5v version , 3.3v version is same)

VIH(input high level)----->min=2.0v typ=x max=3.3v

VIL(input low level)----->min=x typ=x max=0.8v

VOH(Output high level) --->min=2.6v typ=x max=x

VOL(Output low level) --->min=x typ=x max=0.4v

2. GENERAL SPECIFICATIONS

2-1. Input power requirements

Operating voltage range:

MT752 5V DC \pm 5% (4.75 – 5.25V)

MT752L 3.3V DC \pm 5% (3.135 – 3.465V)

2-2. Power consumption

	MT752	MT752L
Working Power Consumption	<825 mW	<594mW
Working current	Typ: 150mA Max:165mA	Typ: 160mA Max:180mA

Standby current	Typ: 80 mA Max:90mA	Typ: 100 mA Max:110mA
Surge Power on Current	Typ: 450mA Max:600mA	Typ: 500mA Max:650mA
Sleep Mode:	Not Available	200uA
Power Down Mode	Not Available	< 1uA, (Refer to 1-2 pin assignment, Pin4)

2-3. Scanning performance

Light source:	Visible red LED array (635nm)
Ambient Light:	70,000 Lux (Fluorescent Light)
Sensor:	CCD
Scan rate:	530 Scans/sec
Printing Contrast Scale:	45%
Best Resolution:	0.1 mm (4 mil)
Depth of Field:	use Marson barcode test chart

MT752 / MT752L D.O.F and Scan Width

	D.O.F	Scan Width
4mil Code39	20 – 40 mm	-----
5mil Code39	20 – 50 mm	45mm @ 40mm
10mil Code39	25 – 80mm	70mm @ 60mm
15mil Code39	30 – 100mm	80mm @ 70mm

* Lighting condition: 300 Lux

2-4. Interface

Decoded Output: UART
Contact: 12 Pin ZIF connector
(Please refer to Section 1-2 for Pin Assignment.)
Support external interface: UART / USB

2-5 Physical Requirements:

Dimensions: 3.2 cm x 2.4cm x 1.1 cm
Weight: 8 grams ± 2g
Connector: 12 Pin ZIF

3. ENVIRONMENTAL CONDITIONS

3-1. Operating temperature

0 ~ 50 °C

3-2. Storage temperature

-20 ~ 60 °C

3-3. Relative Humidity

20% ~85% RH non-condensing

4. READING SPECIFICATIONS

4-1. Symbologies

[MT 752 / MT752L](#) is support read following symbologies.

- | | |
|----------------------|----------------------|
| ■ Standard CODE 39 | ■ Full ASCII CODE 39 |
| ■ Interleaved 2 of 5 | ■ China Postal Code |
| ■ Codabar | ■ Code 32 |
| ■ MSI Plessey Code | ■ Code 11 |
| ■ Industrial 2 of 5 | ■ Matrix 2 of 5 |
| ■ Telepen Code | ■ UK Plessey Code |
| ■ IATA Code | ■ Code 93 |
| ■ EAN-13 | ■ EAN-8 |
| ■ UPC-A | ■ UPC-E |
| ■ Code 128 | ■ EAN / UCC 128 |
| ■ RSS-14 | ■ RSS-Limited |
| ■ PDF417 | |

4-2. Reading direction

This engine can read barcode in right or reverse direction.



Right position



Reverse position

4-3. Operating mode

The **MT 752 / MT752L** CCD Module defaults setting by Continuous MODE.

(Please refer to user manual in Group 2 Section for Reading Mode setting.)

- ※ 1. The LED will be switched on if switch button is triggered.

4-4. SCANNING RANGE

MT752 / MT752L Scanning Range

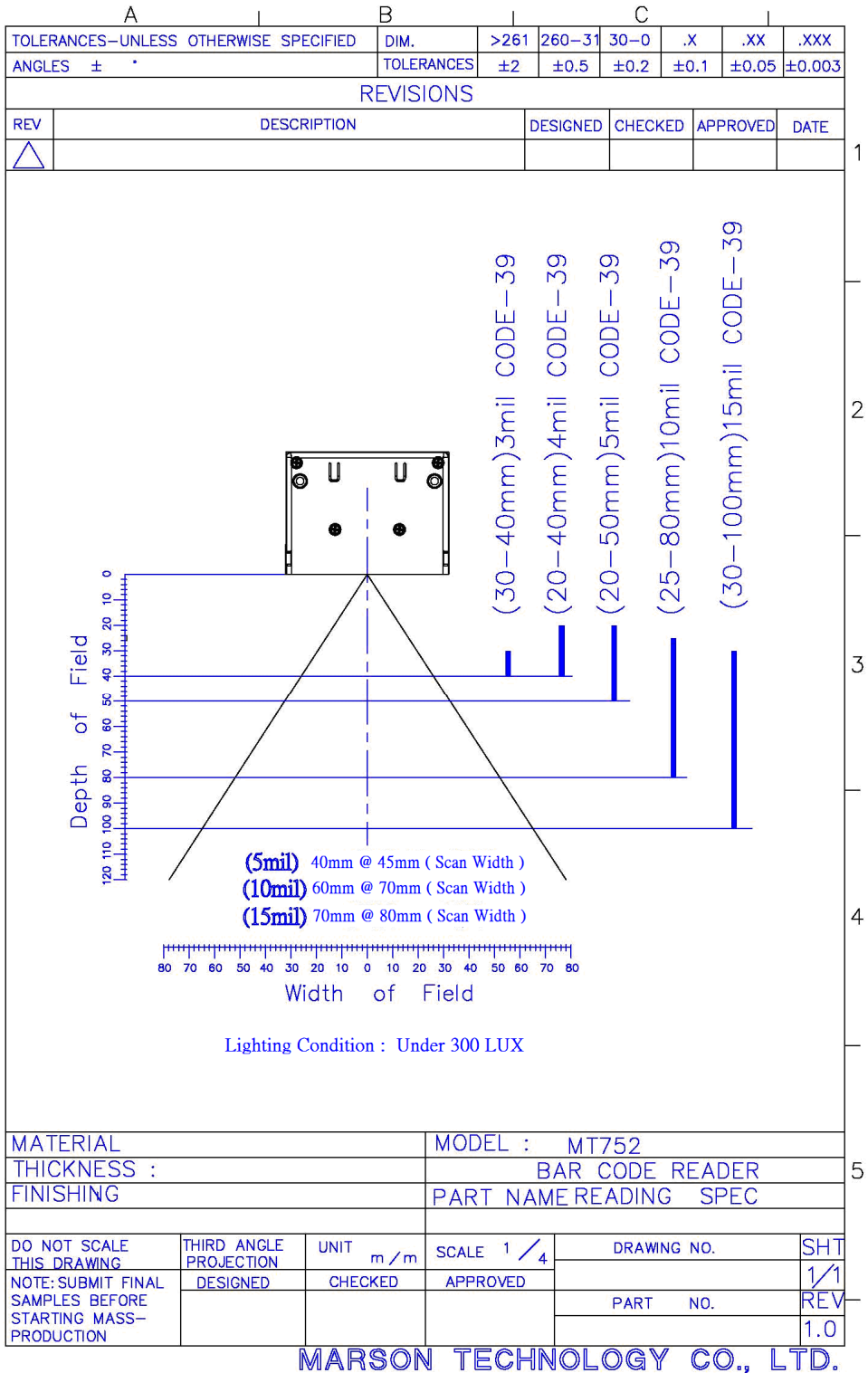

5. Mechanical Integration

This Chapter describes how to mechanically integrate the [MT 752/ MT752L](#) and contains::

5-1 Mechanical Dimensions

- 5-2 Mounting a Window
- 5-3 Lighting and Aiming Beam Location and Reading Position
- 5-4 Tilt Angle Pitch angle and Skew angle
- 5-5 Curvature degree
- 5-6 Ribbon Cable Specification

5-1 Mechanical Dimensions

The interface connector location and the scan light path, this can be the reference material for OEM's design.

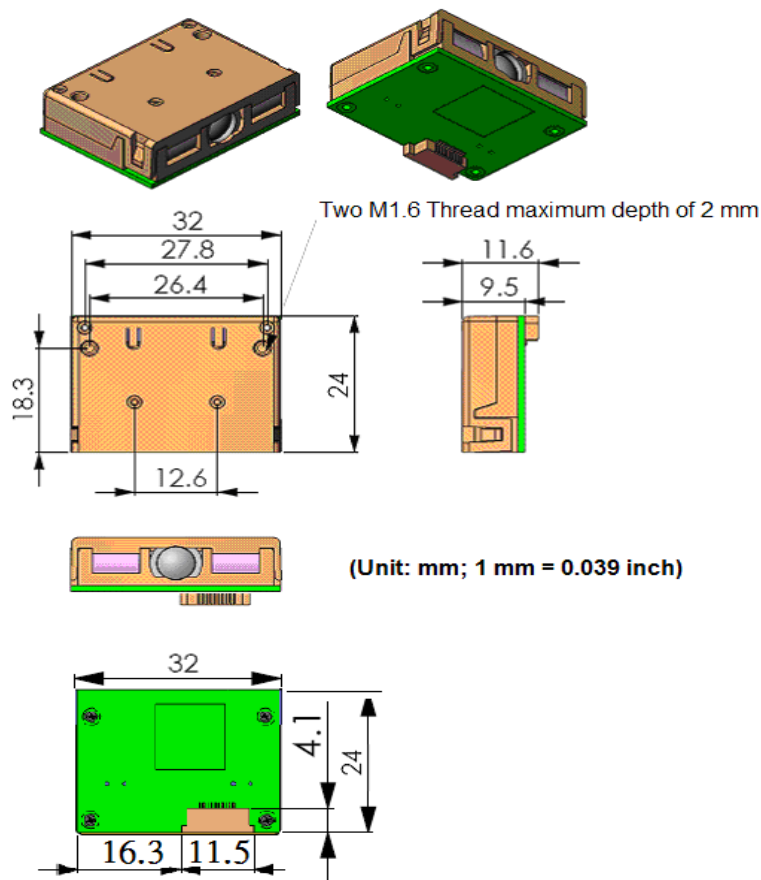

Torque for screwing mounting is suggested $< 3\text{Kgf}$.

5-2 Mounting a Window

To mount an exit window, you need to consider:

- . Material

- . Position and thickness
- . Dimensions
- . Lighting and aiming beam
- . Location and Reading Position
- .Torque for screwing mounting

If you are using the [MT752/ MT752L](#), you need to be aware of the tolerance for the tilt , pitch and skew of bar code you are trying so scan.

To mount an exit window, you need to consider:

Part of Optical :

For the scan module to achieve the best performance, the damage of optical Components have to be reduced. There are some things have to be noticed :

- Avoiding to scrub the optical surface and never wipe the optical surface with dry cloth.
- For protection , you may spray glass cleaner on non-abrasive cleaning cloth, and then gently wiping the module window.
- Keep away from any of the optical component , it is because that optical components may damaged when you touch them.

In the Electrical Part :

Avoid the damage of integrated circuits, and other components in scan engine , which caused by static electrical discharge . There are some things have to be noticed :

- The module should be put in the anti-static case all the time, until you are ready to install it in your device.
- Pay attention to the use of grounding wrist straps and properly grounded when handling the module.

Material

Item	Specification
Spectral Transmission	85% minimum from 640 to 690 nm

Material	Glass, Acrylic(see notice 1)
Window Aperture	(see the figure below)
Coating	Inside and / or outside to be anti-reflection coating on the window, The coating must provide 1% maximum reflectivity from 640 to 690 nm at the window. (An anti-reflection coating can reduce the light that is reflected back to the host case.)
Window Placement	Determining the window tilt angle is important because a part of the emitted light will always be reflected back from the window surface. Note : This reflective light cannot reach the photodiode of the scan module.

Notice 1 : Acrylic has superior optical qualities and relatively good impact resistance at a low initial cost. However, acrylic has surface sensitivity to environmental factors including chemicals, mechanical stress, and UV light, Commonly produced by extrusion, cell casting, or injection molding, acrylic is suitable for ultrasonic welding.
Recommends use an anti-reflective (AR) coating on both sides of the window.

5-3 Window Aperture & Placement, Lighting & aiming beam and Location and Reading Position for [MT752](#) / [MT752L](#)

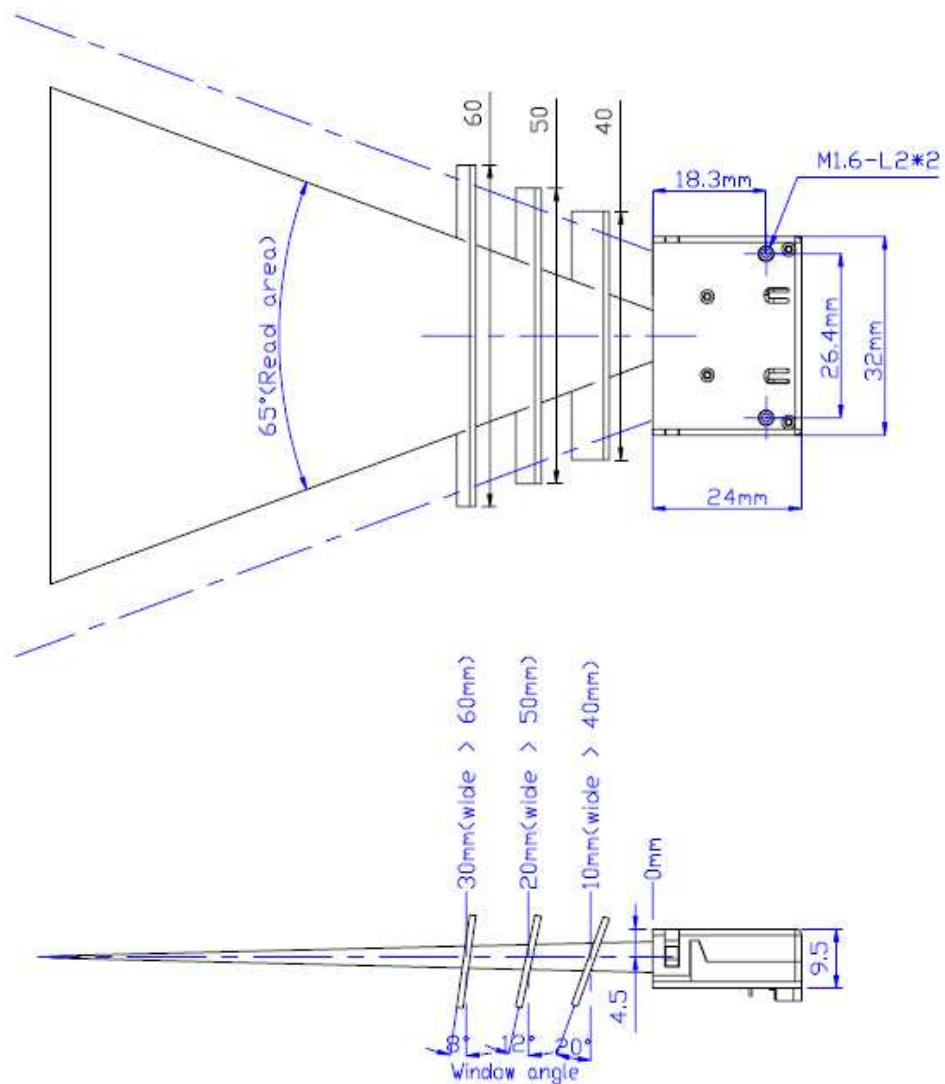

Host Window Care

In the aspect of window, the performance of scan modules will be reduced due to any kind of scratch. Thus, reducing the damage of window, there are few things have to be noticed.

- Avoiding to touch the window as much as possible.
- When clean the window surface, please use non-abrasive cleaning cloth, and then gently wipe the host window with the cloth that is already sprayed with glass cleaner.

Window Positioning and Design Consideration

The function of window includes that avoiding dust get into host case and protecting the scan module.

The [MT752/MT752L](#) scan engine aiming beam through the device's window (or host window) however, some of the beam will reflect back to the host case without through the window, which caused by the window surface. This beam may result in the reduction of the scan module performance and it is due to the improperly positioned window, it can improve the phenomenon that mentioned above and then the scan module can be showed the optimum performance. Suggestion for the window to avoid the reflective light is shown as below.

Note : In order to avoid the reflective light to get to the light beam of the scan engine from the host window surface, so that determining the host window tilt angle is very important.

5-4 Tile angle, pitch angle and skew angle

If you are using the [MT752](#) / [MT752L](#), you need to be aware of the tolerance for the roll angle, tilt, pitch and skew of bar code you are trying to scan.

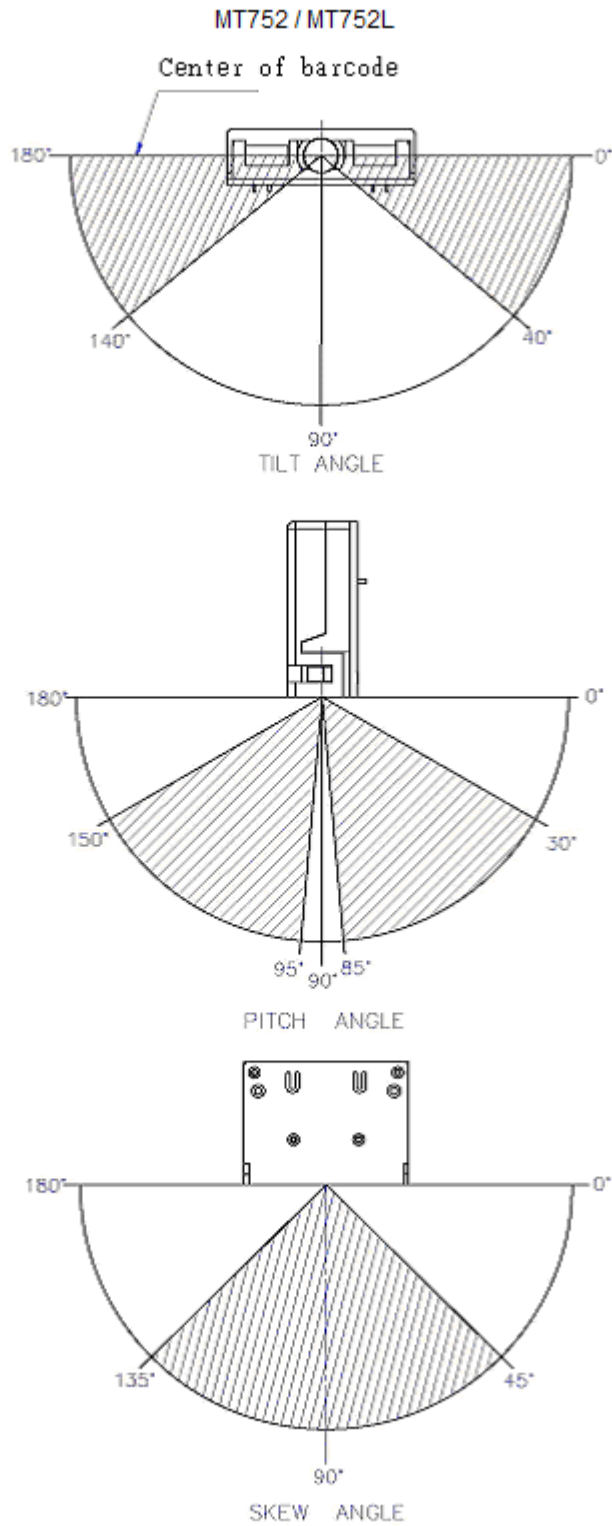

5-5 Curvature Degree

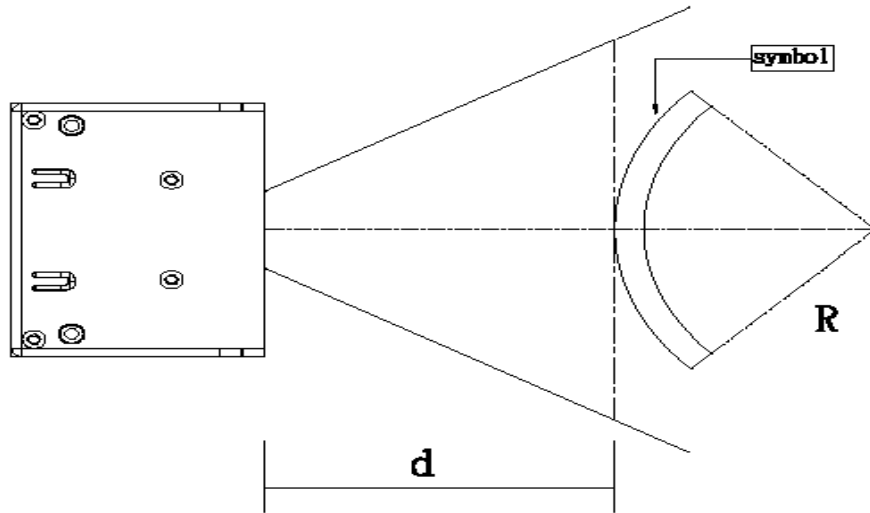

Symbol	EAN (13 digits) 37 mm	
	0.33 mm (13 mil)	0.39 mm (15.6 mil)
R	$R \geq 20 \text{ mm}$	$R \geq 25 \text{ mm}$
d	40 mm	50 mm
PCS	0.9 (printed on photographic paper)	

5-6 Ribbon Cable Specification

Ribbon cable Specification

Contact : $12 \pm 0.5 \text{ mm}$

Length : $100 \pm 3 \text{ mm}$

Refer to Section 1-2 Pin Assignment for Ribbon cable connection.

單位(UNIT): mm

項目(Item)	規格(Spec.)
導體數(Number of conductor) :n	12
間距(Pitch) :P	0.5±0.03
總間距(Total Pitch) :TP	5.5 ±0.05
制品寬(Width) :W	6.5 ±0.05
制品厚(Thickness) :T	0.11 ±0.05
邊寬(Margin width) :M	0.35±0.1
絕緣長(Insulation length) :L	112 -3
剝離長(Strip length) :S	3 ± 0.5
端子厚(Terminal thickness) :t	0.30±0.05
補強板長(Supporting tape length):d	5 ±1.5
導體寬(Conductor width) :A	0.3 ^{+0.05} _{-0.02}
導體厚(Conductor thickness) :B	0.035±0.02

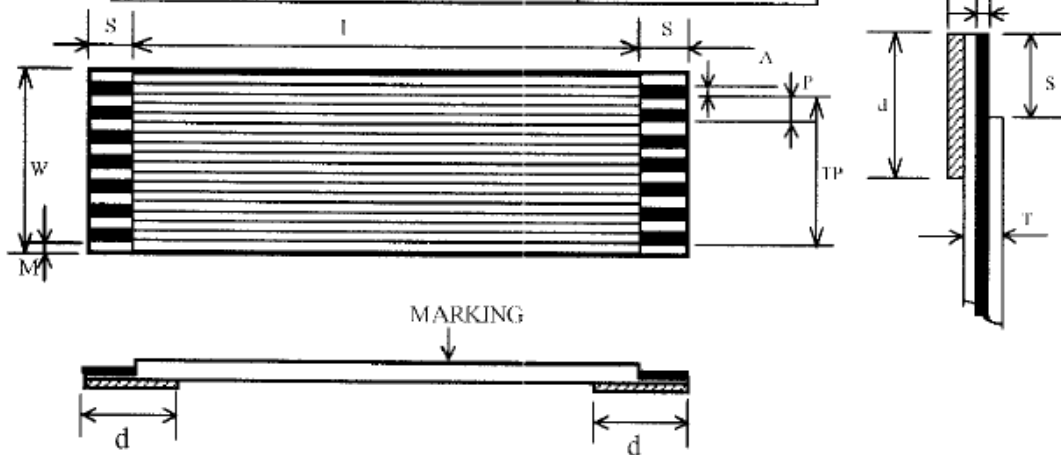

6. Downloading Firmware

- Reserved for [MT752](#) / [MT752L](#) with decoder use only.

Firmware Update Procedure

< Hardware Preparation >

Before a firmware downloading you need hardware preparation as following:

1. [MT752](#) 5V CCD Scan Engine, Marson P/N: [1752-0201A00](#) or [MT752L](#) 3.3V CCD Scan Engine, Marson P/N: [1752-0201A10](#)
2. USB Virtual Com Cable, Marson P/N :7505-9204A61
3. Demo Board, Marson P/N: 2001-0036A02
4. Marson Updated Firmware
5. A computer installed Microsoft OS with Hyper Terminal program.

SW2

5V/3.3V Selection	
5V	<input type="checkbox"/> ON <input checked="" type="checkbox"/> OFF
3.3V	<input type="checkbox"/> ON <input checked="" type="checkbox"/> OFF

MT752 Series
MT742 Series

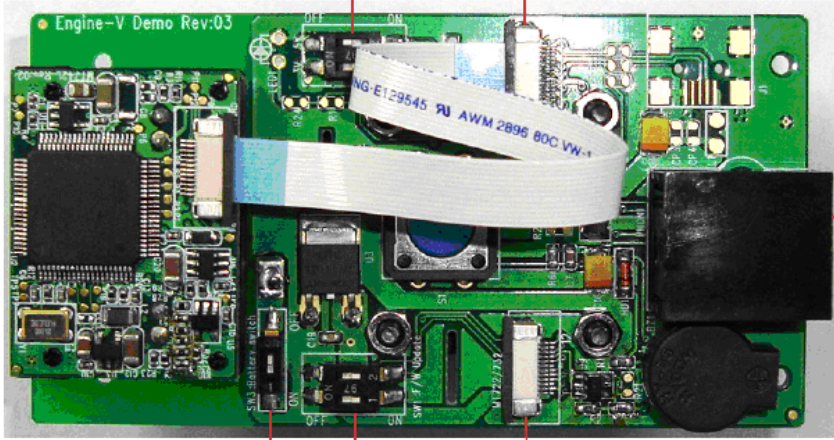

MT722 Series

MT732 Series

Interface Cable matrix table

Interface \ Model	MT722 / MT732 Series	MT 742 / MT752 Series
RS232 Interface Black Cable (P/N: 7302-7704*05) 5V Power Supply is required (P/N: 3741-0013*00)	0	X
USB (HID) Interface Cable (P/N: 75059204A51)	0	X
USB (Virtual Com) Black Cable + CD Driver (P/N: 7505-9204A61)	0	0
Mini USB Cable (P/N: 7005-9296A50)	X	USB TBD FW is not support

CCD Engine Demo Board (P/N: 2001-0036*XX) 0: Supported X: Not Supported

SW3

9VDC Battery SW	
ON	<input checked="" type="checkbox"/>
OFF	<input type="checkbox"/>

! While this unit is not in use, please switch off to save battery power.

SW1 F/W Update

F/W Update	Normal Operation
MT722 <input type="checkbox"/> ON <input checked="" type="checkbox"/> OFF 16 Bit MCU MT732 <input type="checkbox"/> ON <input checked="" type="checkbox"/> OFF	<input type="checkbox"/> ON <input checked="" type="checkbox"/> OFF
MT742 <input type="checkbox"/> ON <input checked="" type="checkbox"/> OFF 32 Bit MCU MT752 <input type="checkbox"/> ON <input checked="" type="checkbox"/> OFF	<input type="checkbox"/> ON <input checked="" type="checkbox"/> OFF

[Back View]

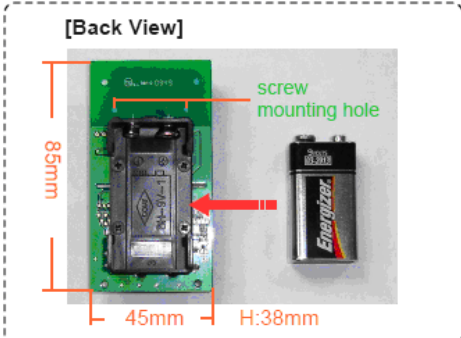

Before download firmware, refer to the demo board to set SW1 to off position.

< Download an updated firmware from computer to MT752 / MT752L CCD Scan Engine >

1. Execute Hyper Terminal program, set up RS232 communication parameter as 115200 for Baud Rate, 8, N, 1 , to connect Hyper Terminal program online.

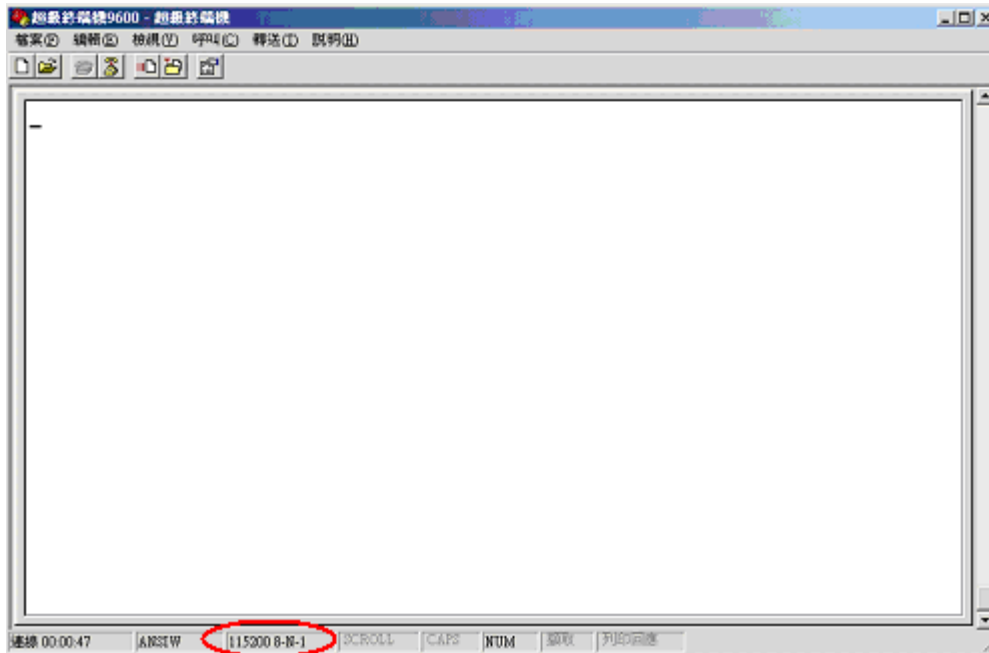

< Fig 1 >

2. Press the trigger of Demo Board (do not release trigger) plug in USB virtual cable to Demo board with MT752 or MT752L, then Hyper terminal appears a screen as fig 2. : (sometime it not appears, or not completely appears).

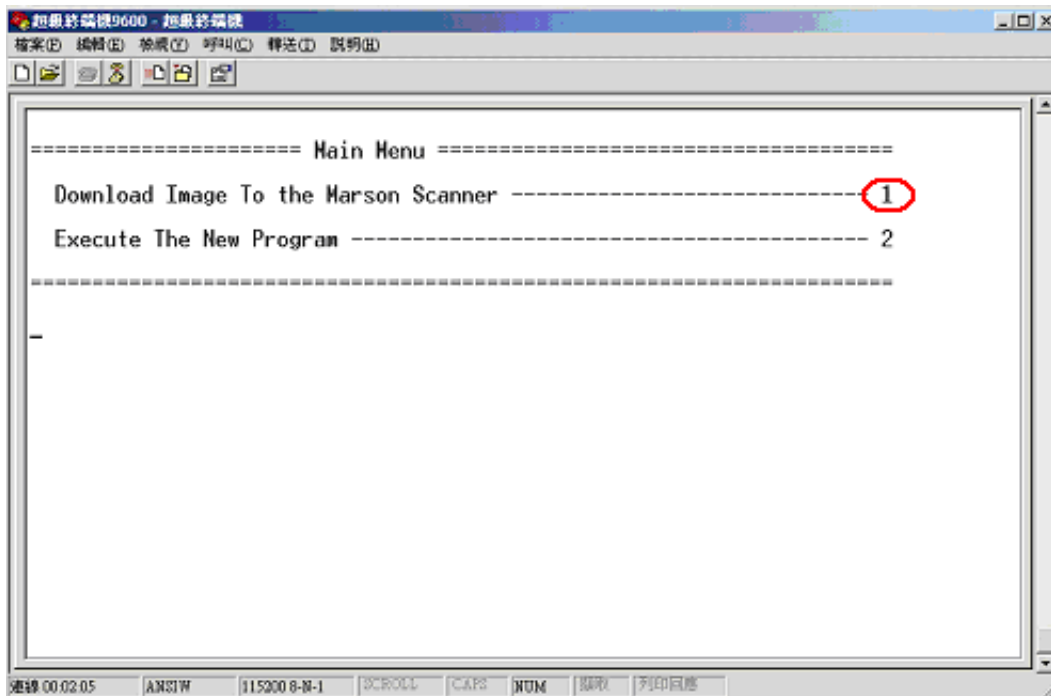

< Fig 2 >

3. Use keyboard device press “1” for Download Image to the Marson Scanner , then computer will display a status of connection is as following screen < Fig 3 >; it is shown that link connections is successful. If your computer is shown “ Waiting for the file to be sent” message, please repeat Step 1, procedure, until computer is showing message ”Waiting for the file to be sent ...”

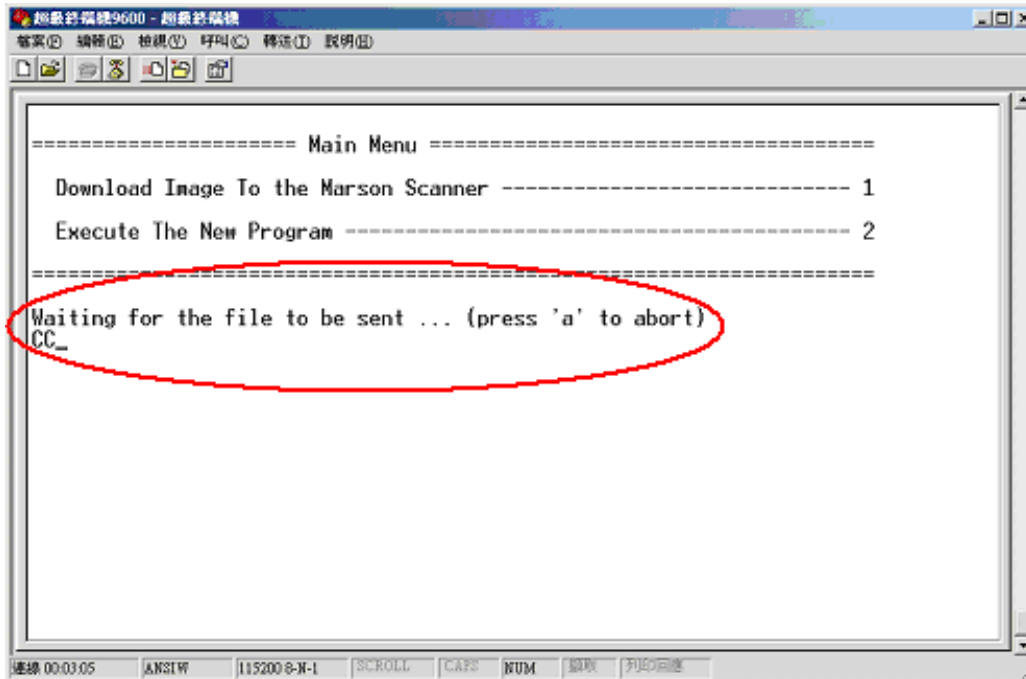

< Fig 3 >

4. Refer to < Fig 4 >
 - 4-a. Browse an updated firmware name (*.bin)
 - 4-b. Select “ Ymodem “ for communication protocol.
 - 4-c. Click “ (S)end “ send *.bin file to begin with firmware update

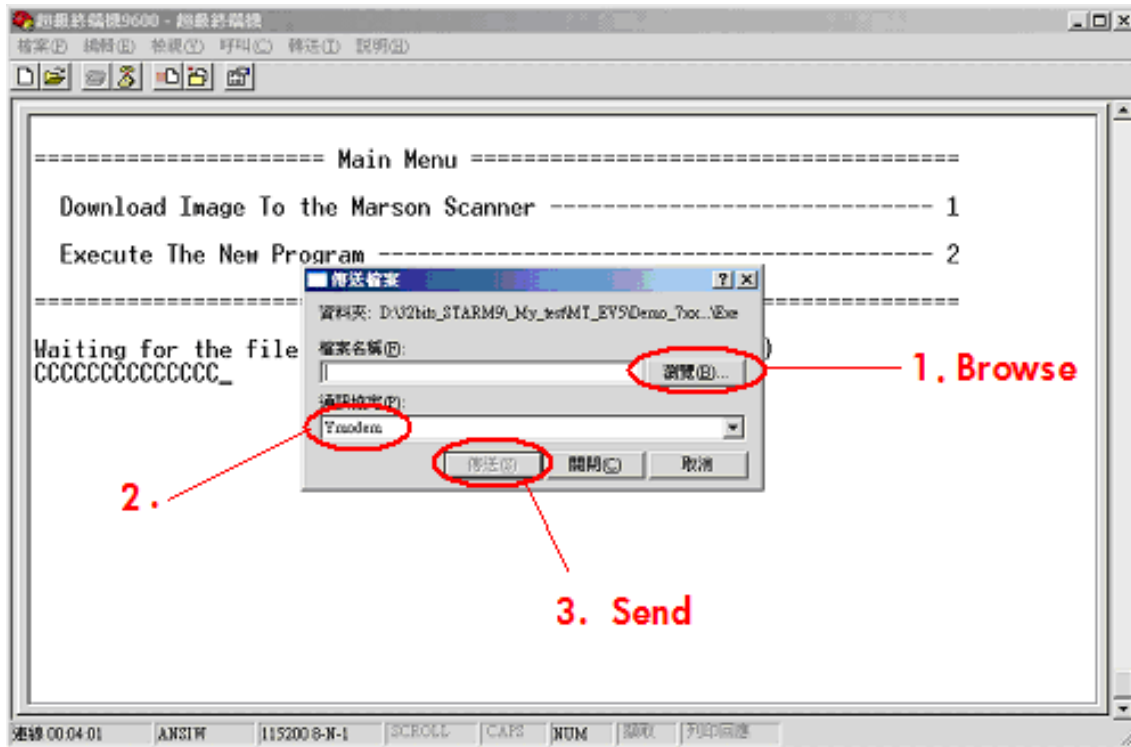

< Fig 4 >

5. Hyper terminal program will pop up a screen as <Fig 5>

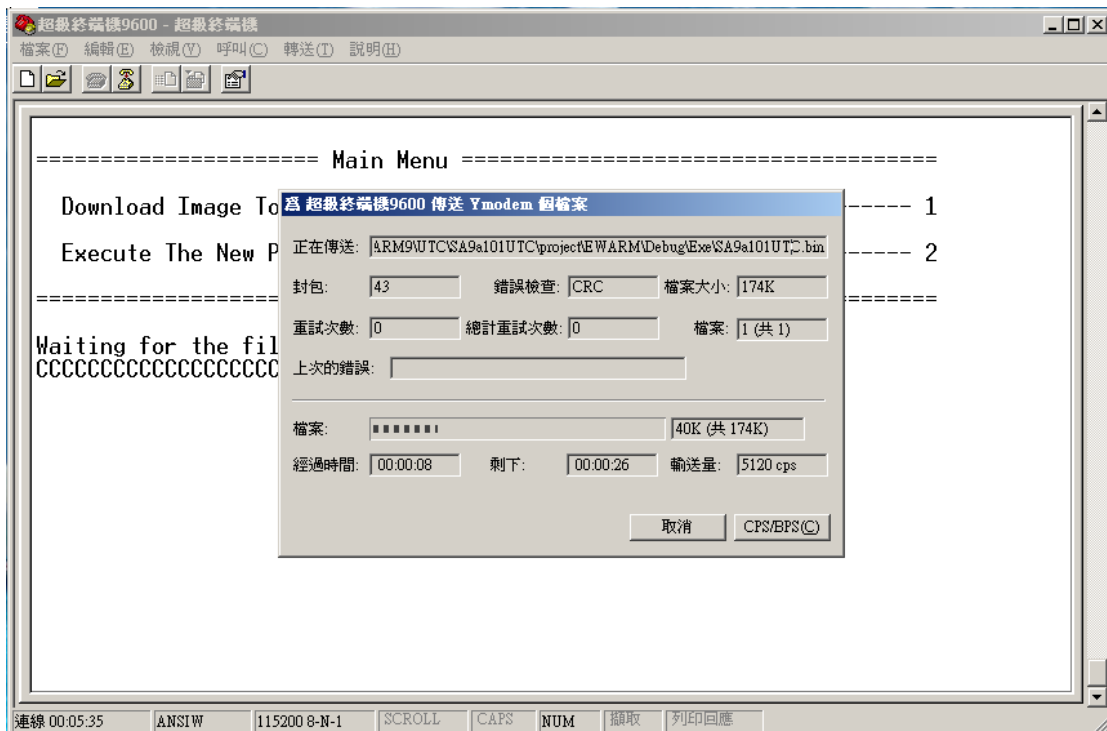

< Fig 5 >

6. After new firmware programming is completed, Hyper terminal program will

appear “ Programming completed Successfully “ then press “2” , your will hear a boot up beep to end of download sequence.

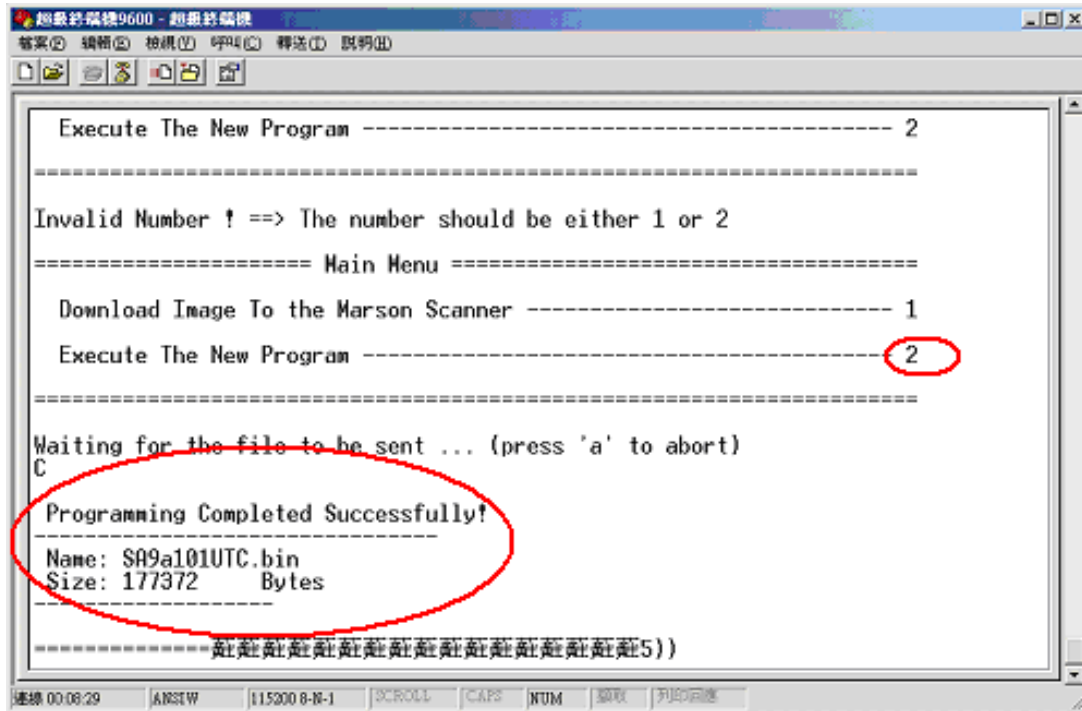

< Fig 6 >

7. APPLICATION

Feature:

- Quick and easy integration
- Excellent scanning performance on all type of bar codes including (RSS) symbology.
- Optimized for rapid reading of 1D symbologies quickly and accurately.
- Small and compact size

Application:

- POS
- KIOSK
- PDA
- Potable data collector

Application example:



8. SAFETY APPROVAL

The [MT752](#) / [MT752L](#) are under certifying by CE, FCC (class B), / RoHS/ WEEE.

9. VERSION HISTORY

Rev.	Date	Description	By	Checked
1.0	2009.10.2	Preliminary released	H.Johnson	Kenji Wu
1.1	2009.12.11	1.Updated for window placement and Curvature Degree 2. Added ribbon cable drawing	H.Johnson	Kenji Wu
1.2	2010.3.2	Changed Demo Board Part Number	Kenji Wu	Andy Liu

1.3	2010.3.30	1.Added Ribbon connector drawing on the CCD engine unit 2. Added windows glass wide size for window place design	Kenji Wu	Andy Liu
1.4	2010.10.14	For MT742L 3.3V model 1. Added power consumption for power enable is off, current is <1uA 2.Added Sleep mode specification 200uA	Kenji Wu Johnson Han	Andy Liu
1.5	2011/1/14	1. Revised LED Wavelength from 660um to 635nm. 2. Defined I/O characteristics for internal operate voltage VDD=3.3v and 5v version 3. Revised power current specification	Kenji Wu Johnson Han	Andy Liu



Technology Co., Ltd.

9F., 108-3, Min-Chuan Road, Hsin-Tien,

Taipei, Taiwan

TEL: 886-2-2218-1633

FAX: 886-2-2218-6638

E-mail: info@marson.com.tw

Web: www.marsontech.com